

# Assembling Your Huot WorkTable FrameWork

Tools needed: Drill press or hand Drill, 9/32" Drill Bit, 7/16" Box Wrench, 7/16" Socket and driver

## STEP 1

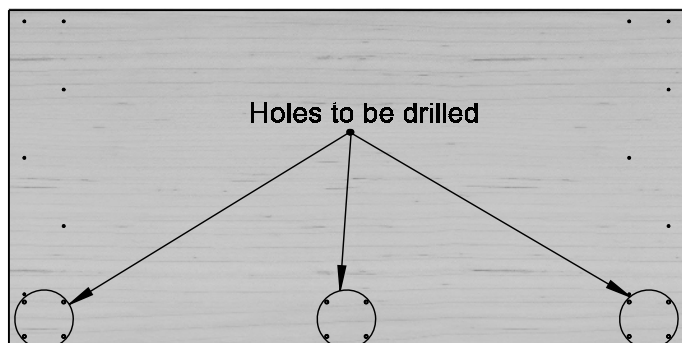

1) Notice the 12 larger partially-drilled holes on the underside of the table. With wood top unattached to the WorkTable carefully complete the 12 holes shown with a 9/32" drill bit. Be sure drill is held straight, and to avoid splintering DO NOT drill with excessive force.

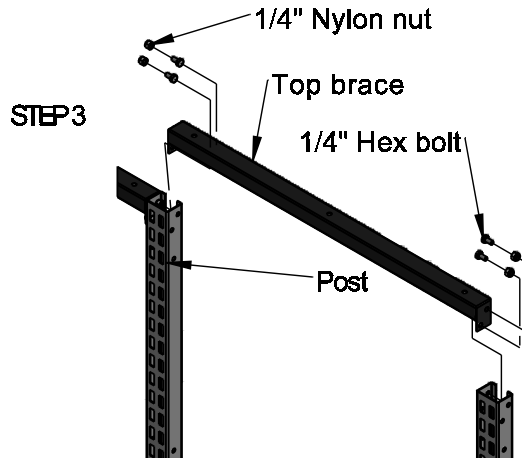

3) Attach each of the two top braces to two posts using four 1/4" hex bolts and four 1/4" nylon nuts.

4) Now tighten all fasteners.

## STEP 2

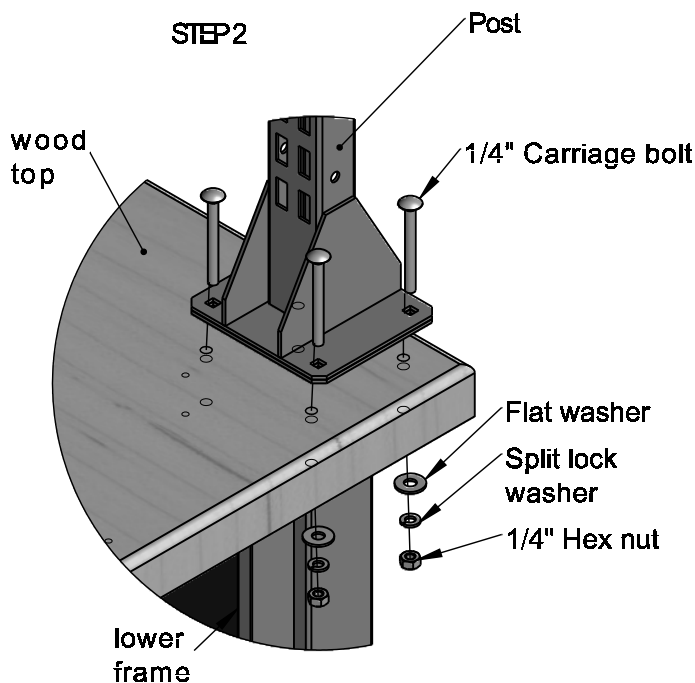

2) With wood top in position and secured on the lower frame, attach each post to the WorkTable by loosely installing four each: 1/4" carriage bolts, flat washers, split lock washers, and 1/4" Hex nuts.

## STEP 5

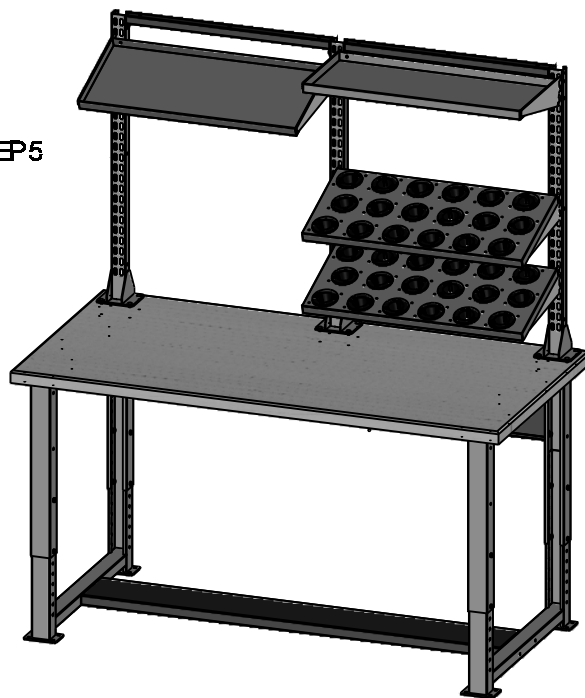

5) Place Shelves (sold separately) in desired locations. Your WorkTable with FrameWork is now ready to be used.

6) Check all fasteners periodically to ensure tightness.

HUOT MFG. CO.  
550 N Wheeler St.  
St. Paul, MN 55104



Ph: (651) 646-1869  
Fax: (651) 646-0457  
www.Huot.com